



910026NT Freeze Protection Valve

Working principle :

The Freeze Protection Valve is designed to protect water pipe by preventing the water from freezing when the water temperature drops.

When the water temperature falls below 3.8 °C, the thermostatic element opens the valve, thereby allowing the water flowing out from the waterpipe and reducing the change of the water freezing in the waterpipe.

Once the water temperature reaches 3.8 °C, the Freeze Protection Valve will close again and the water will stop flowing.

Technical parameter :

Application :

Material:Brass	Sanitary
Initial Open: 1.6°C	Heating and cooling system
Full Open: 4°C	Solar and electric water heating system
Full Close: 7°C	
Working Temperature:-30 - 80°C	
MAX Pressure:1MPa	
Max Flow:20L/min(300KPa)	
Control Accuracy:±1°C	
Thread Specification:G3/8-19,G3/4-14	

Customize Solution :

If you are not sure about the parameters of thermostatic mixing valve, our engineering team will assist you with your selection or customization according to these details as follow:

- Water temperature range
- Pressure and loss of pressure
- Custom material and other parts

Dimensions:

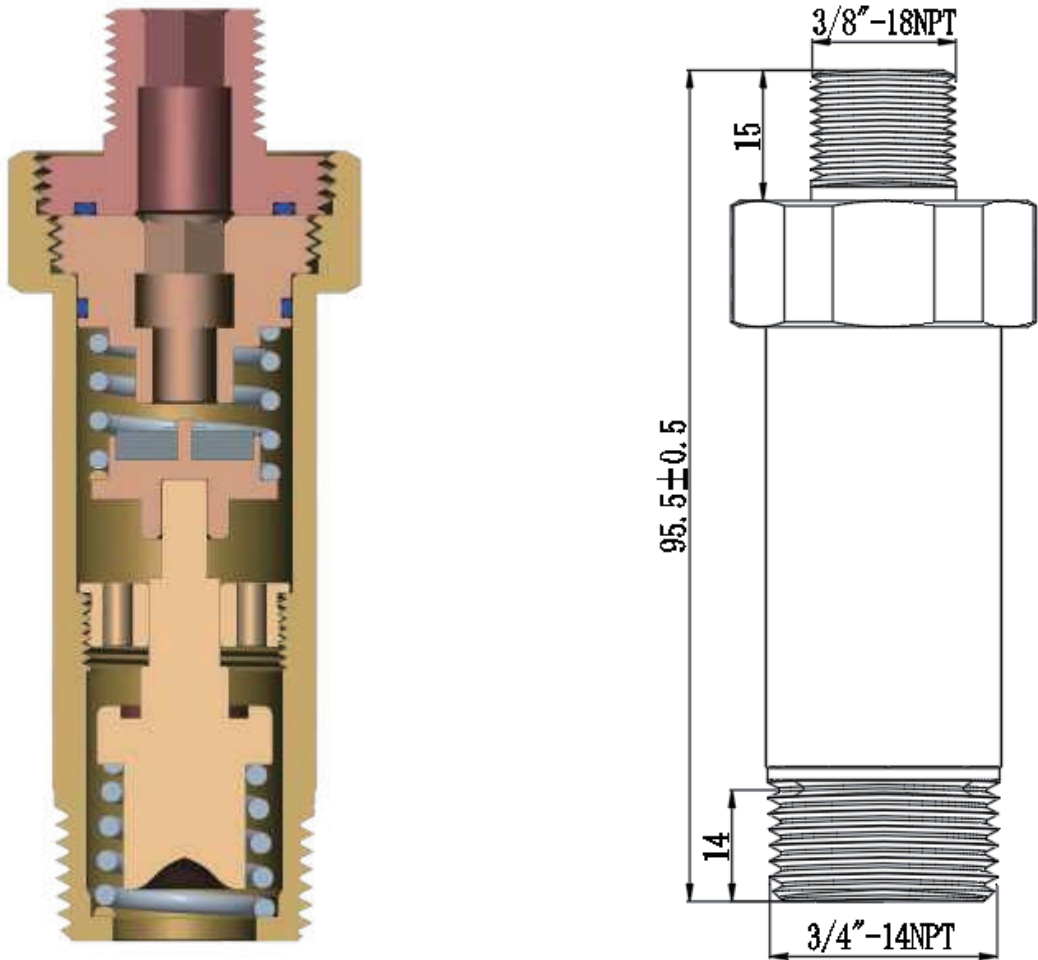

Flowing Curve:

