

# 910024CC Solar Thermostatic Connection Kit

## Working principle :

According to the temperature set by the reversing valve (45 degree), reversing valve between the solar system and boiler system to realize automatic shunt switch. The reversing valve will fine-turning way to use solar energy in middle low temperature hot water in water tank, reduce the times for the boiler frequent open. The thermostatic mixing valve will provides a safe and comfortable hot water temperature in the kit.



## Technical parameter :

## Application :

Material: Brass +ABS cover	Sanitary
Maximum Static Pressure: 10Bar	Heating and cooling system
Max Differential Pressure: 5Bar	Solar and electric water heating system
Max. Inlet Temp: 100°C	
Setting Temperature: 45°C	
Control Accuracy: $\pm 2^{\circ}\text{C}$	
Mixing Water Temperature: 2:1	
The Minimum required flow for work: 4 L/min	
Standard: EN1111 EN1287	

## Customize Solution :

If you are not sure about the parameters of thermostatic mixing valve, our engineering team will assist you with your selection or customize according to these details as follow:

Mixing water temperature range

Pressure and loss of pressure

Performance standard

Custom material and other parts

# Dimensions:

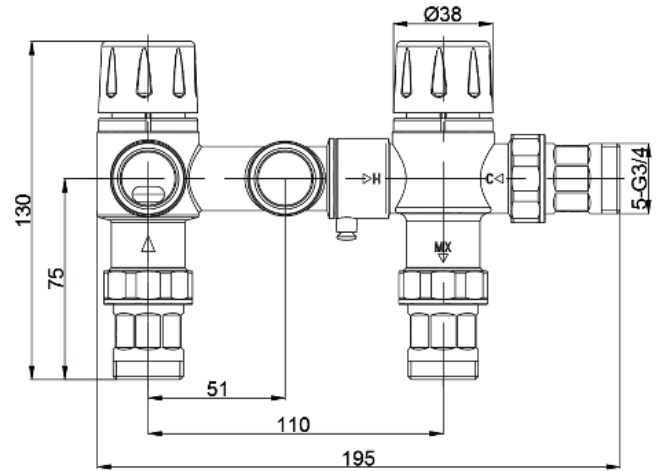
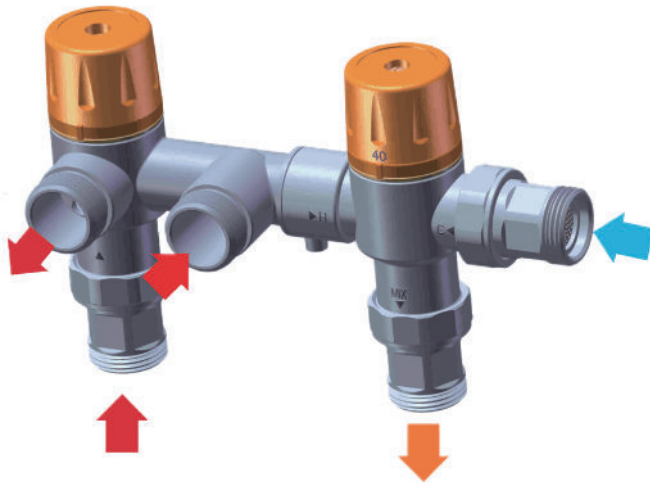

# Installation Instruction:

