

CATALOGUE

RFDN15

Thermostatic Mixing Valve Instruction

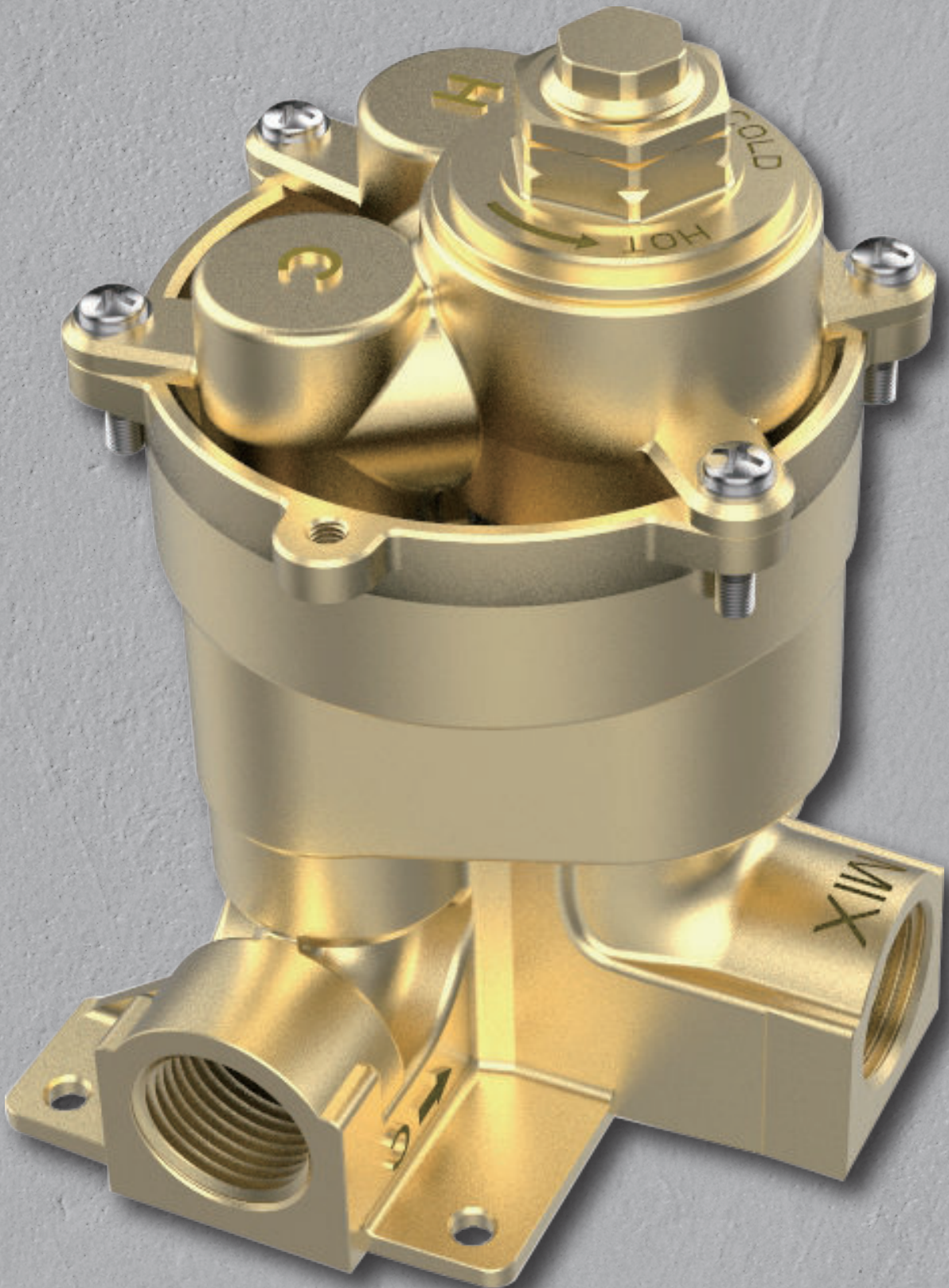

1、Description

RFDN15 thermostatic water mixing valve is a self-operated thermostatic mixing valve that automatically controls the ratio of cold/hot water inlet by its internal wax thermostatic element to achieve a constant outlet water temperature. It is widely used in hot water supply system, which can effectively solve the problems of unstable temperature and poor comfort during the use of hot water, and has the function of preventing scalding.

2、Product dimension

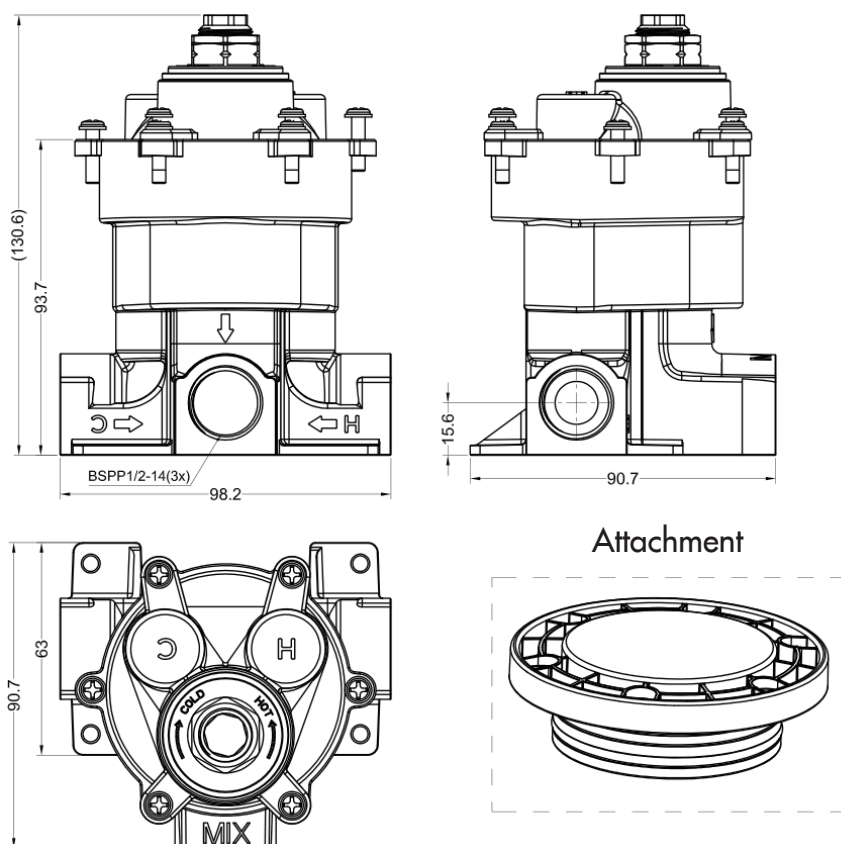

3、Flow characteristic

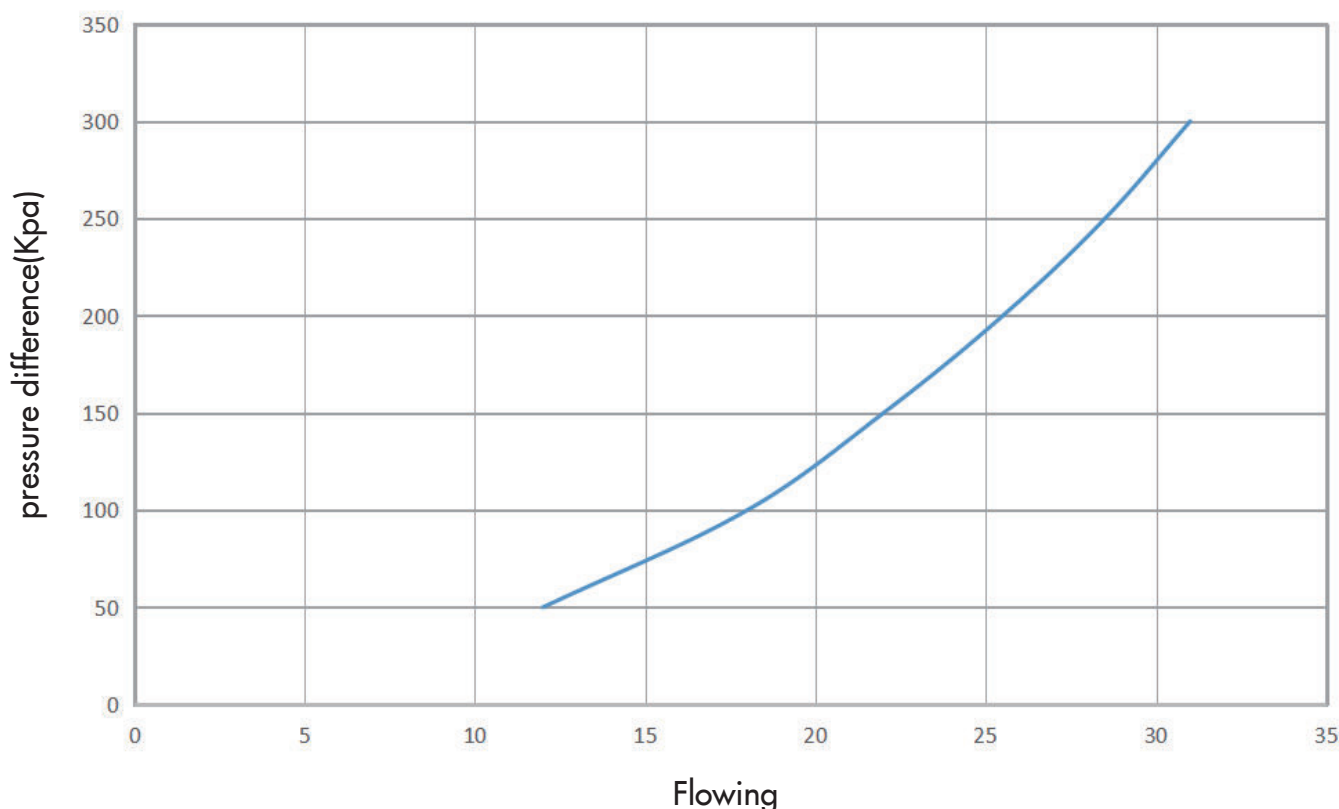

4、 Feature

DZR brass body, compliant with drinking water standards;

Product meets AS4032.2/AS4020/Watermark;

It has the safety protection function of cold water failure and anti-scalding;

PSU plastic piston, strong anti limescale ability and long service life;

Built-in stainless steel filter to prevent impurities from entering;

Built-in check valve to prevent cross flow;

Compact product design and easy installation;

Built-in high-precision wax thermostatic element to ensure the stability of water temperature;

With temperature tamper-proof device;

The temperature adjustment is simple and convenient, no special tools are required.

5、 Technical parameter

Maximum water inlet pressure ratio: 2:1

Minimum temperature difference between outlet water temperature and hot water temperature: 15°C

Hot water temperature: 60-99°C

Cold water temperature: 5-30°C

Outlet temperature range: 30-50°C

Water temperature control accuracy: $\pm 2^{\circ}\text{C}$

Static maximum water supply pressure: 1400Kpa

Dynamic maximum water supply pressure: 500Kpa

Ideal working pressure: 300Kpa

Minimum flow rate: 4L/min

6、 Product installation

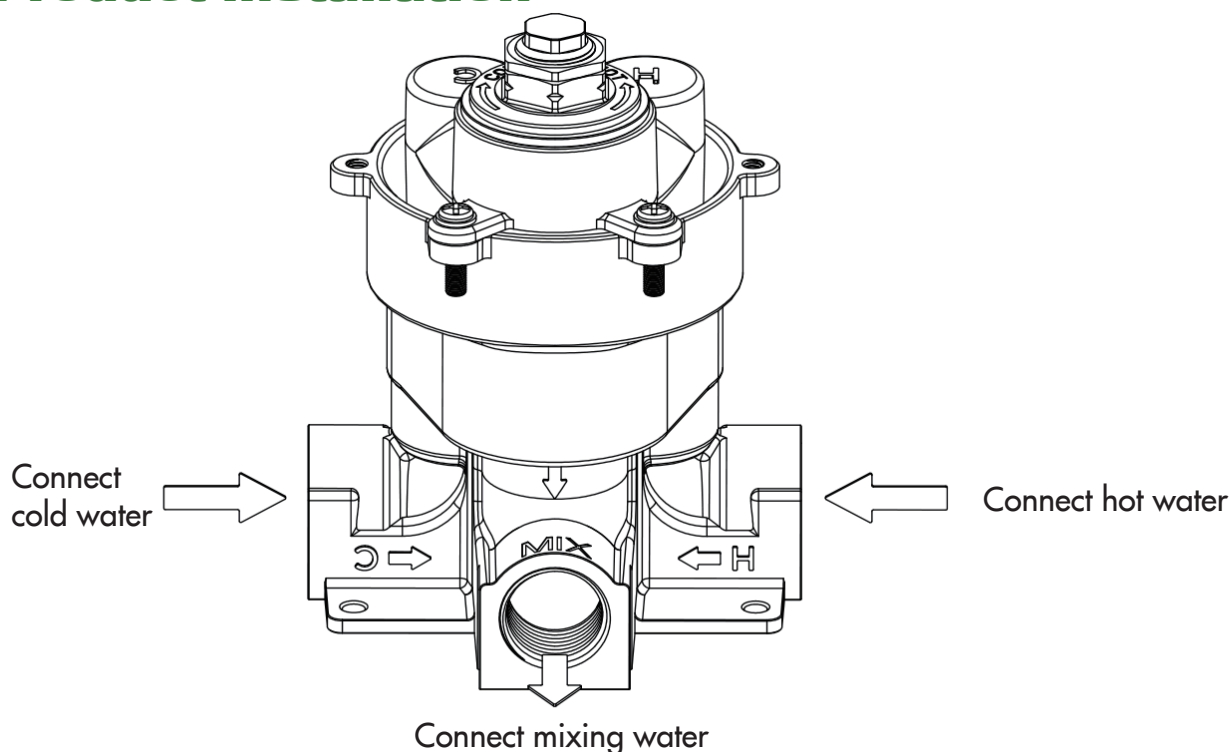

7、Temperature adjustment

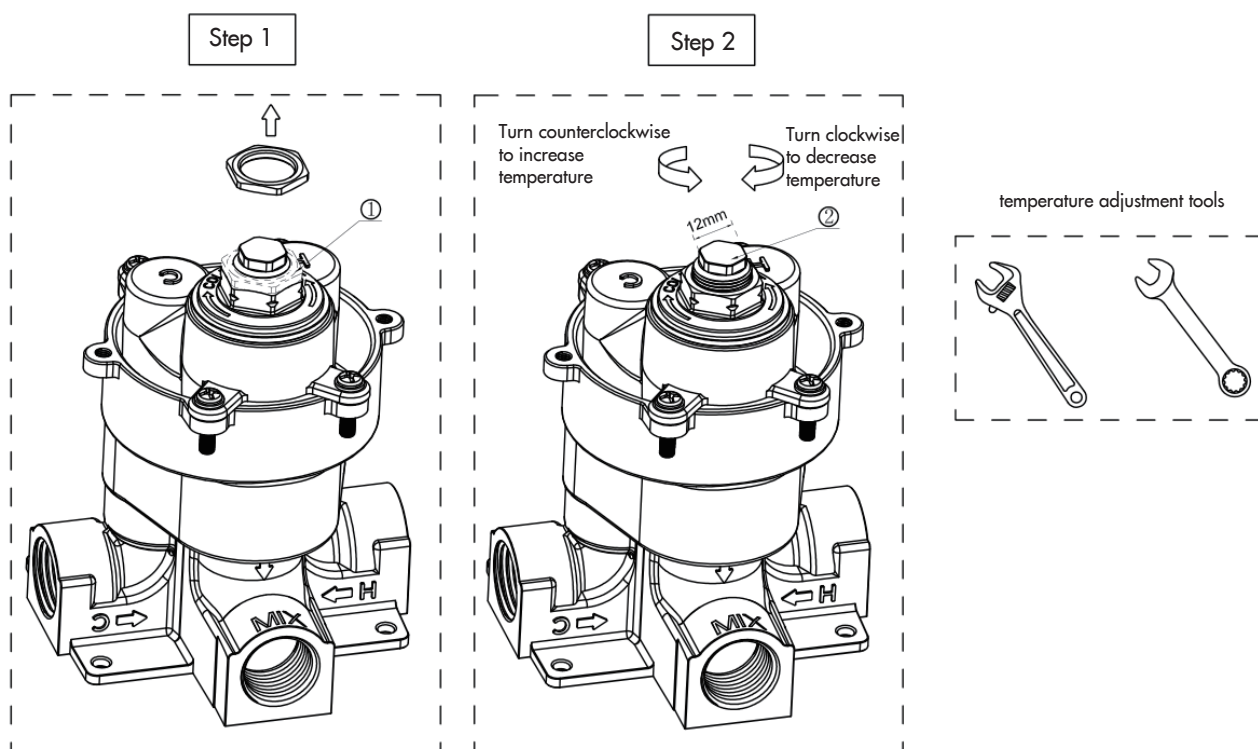

- Use a wrench (refer to the temperature adjustment tool as shown in the figure) to loosen and remove (1) the locking nut;
- Use the wrench to turn (2) the temperature adjusting bolt, rotate clockwise, the outlet water temperature will decrease, turn counterclockwise, the outlet water temperature will increase, and use a thermometer to confirm the outlet water temperature during the temperature adjustment process;
- After the outlet water temperature reaches the required temperature, continue to flow for at least 1 minute to ensure that the outlet water temperature setting is completed. Reinstall (1) the lock nut and tighten it with a wrench to prevent accidental tampering of the outlet water temperature. Be careful not to drive the temperature adjusting bolt during the tightening process, otherwise the temperature may deviate.

8、FAQ&Solution

FAQ	Related system checks	Solution
The outlet water temperature is the same as the cold water temperature, no hot water is mixed in	Check whether the hot and cold water inlets are installed reversely	Change the hot and cold water inlet
The water temperature is obvious higher than set temperature	Check whether the cold water pressure is too low or the cold water pipeline is blocked causing abnormal cold water intake.	Increase the pressure at the outlet of the cold water pump or replace the high-lift water pump to clean the filter screen and remove the blockage in the pipeline.
Outlet water temperature is obvious below set temperature	Check whether the hot water pressure is too low or the hot water line is blocked causing abnormal hot water intake.	Increase the pressure at the water outlet of the hot water pump or replace the high-lift water pump, clean the filter screen, and remove the blockage in the pipeline.
Outlet water temperature is unstable.	When the pressure changes suddenly, the outlet water temperature will be adjusted for a few seconds, which is normal; If the water temperature is never stable, the system pressure should be checked.	Due to the frequent opening and closing of the water pump, a back pressure valve can be installed at the water outlet end of the water pump or pressure tank if the instantaneous pressure suddenly changes. The water pump is installed with a frequency converter or replaced with a variable frequency pump to control the sudden change of pressure caused by frequent opening and closing of the water pump.
The hot water is not automatically shut off when the cold water is shut off.	Check whether a filter is installed at the water inlet. Whether the hot water temperature is higher than 60 °C.	Usually because the filter is not installed, impurities enter the valve core and affect the sealing of the sealing ring, and a filter is installed. Only when the temperature of the hot water source is above 60°C can it play a safe and anti-scalding effect.
No water at the water outlet of the valve	Whether the hot and cold water supply is normal.	The valve cannot be used normally if only one end of the water supply is supplied.

9、Installation precautions

- Before installing the mixing valve, the pipeline must be thoroughly cleaned to remove sundries;
- It is recommended to install a ball valve at the cold/hot water inlet end for later maintenance;
- It is recommended to install the thermostatic mixing valve as close to the water point as possible to reduce unnecessary heat loss;