



LGX066

The wax thermostatic element produced by the SMLG with its own patented formula is widely recognized, praised and applied in the industry for its sensitivity and accuracy. It has also passed the European experimental institutions product certification (ACS, WRAS)

Technical Parameter

Working voltage	24v 110v 220v
Max working temperature	90 °C
Maximum Force	140N
Minimum Force	45N
Testing Force	55N
Spring Rate	1N/mm
Material	Copper
Stroke:L=12±1.2mm	

Start response time<2min, Finish response time<6min

Durability: To make a circle that to increase the test load for 5 minutes and outage for 5 minutes, should control the L change quantity less than 8% after 30,000 times (about 250 days) circles.

Application

- Automobile
- Shipping
- Other industries
- Plumbing
- Air conditioning
- Sanitary
- Military

Customize Solution

If you are not sure about the parameters of thermostatic element, our team will assist you with your selection or customize according to your products' situation. Before any commitment, you need to send us written confirmation for the three performance parameters of the wax thermostatic element (temperature range, working stroke, working voltage and maximum force).

Dimension

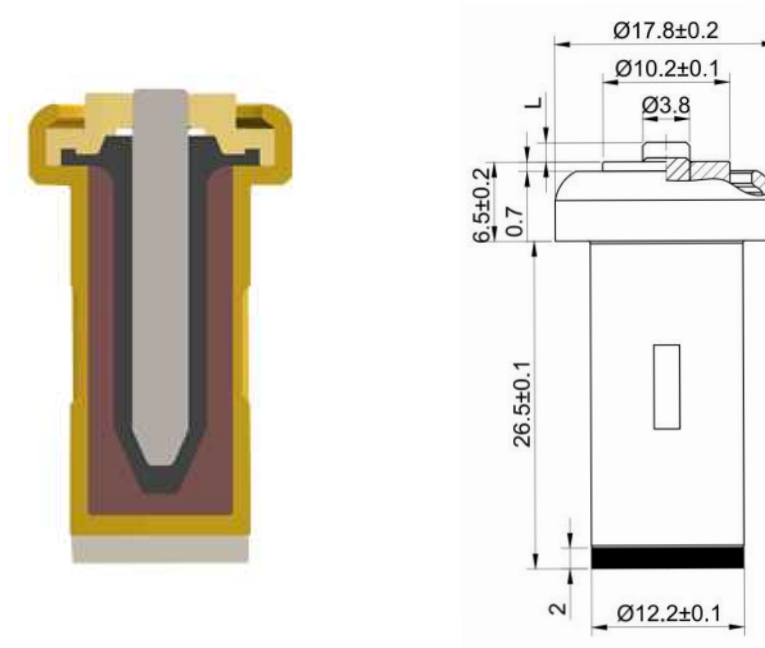

Time VS. Stroke

