

LG013X

The wax thermostatic element produced by the SMLG with its own patented formula is widely recognized, praised and applied in the industry for its sensitivity and accuracy. It has also passed the European experimental institutions product certification (ACS, WRAS)

Technical Parameter

| | | | |
|------------------------------------|--------|-----------------|-------------|
| Maximum Load | 180N | Temperature(°C) | Stroke(mm) |
| Minimum Load | 60N | 45°C ~ 60°C | 2.15 ± 0.25 |
| Testing Load | 75N | 15°C ~ 90°C | < 6mm |
| Spring Rate | 5N/mm | | |
| Maximum Temperature | 90°C | | |
| Material | Copper | | |
| Stroke:L = 19.7±0.25mm at 45°C 75N | | | |
| Lifespan:100000 times | | | |

Application

- Automobile
- Shipping
- Other industries
- Plumbing
- Air conditioning
- Sanitary
- Military

Customize Solution

If you are not sure about the parameters of thermostatic element, our team will assist you with your selection or customize according to your products' situation. Before any commitment, you need to send us written confirmation for the three performance parameters of the wax thermostatic element (temperature range, working stroke and maximum load).

Dimension

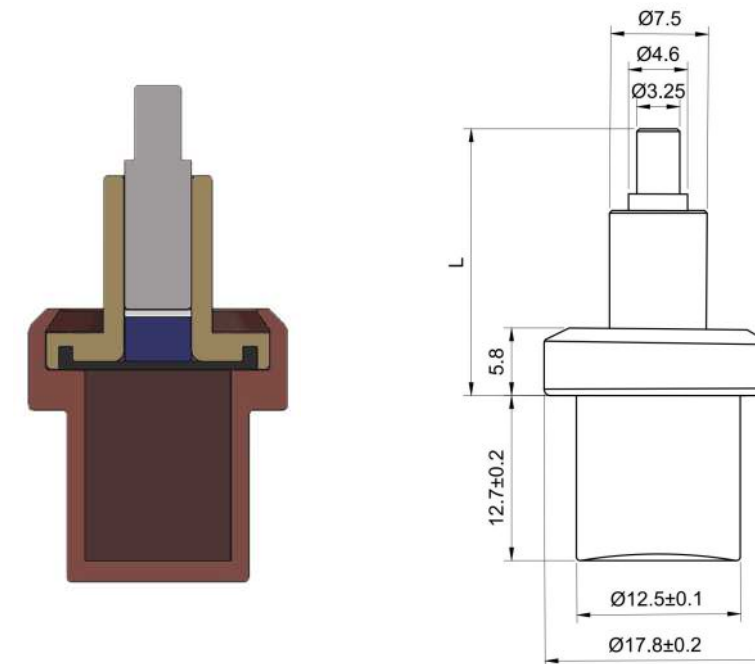

Temperature VS. Stroke

