

Pressure & Temperature Relief Valve

As a dual automatic safety protection device installed in boiler, water heater or controlled pressure storage water heater, PTR valve can prevent excessive temperature and pressure. Wax probe will automatically open the seal mechanism to release the hot water and steam when the temperature and pressure meet the preset rating. In addition, PTR valve will automatically reset quickly to avoid the waste of hot water resource when the pressure or temperature reduced a certain value.



Features

1. All water-touching metal materials are made of DZR, which make the product greater corrosion resistance and longer lifespan.
2. The internal size and structure of the product fully meet the standard requirements, and the water and scale can be quickly drained after pressure relief; the scale-holding capacity is strong, and the sealing of the product will not be affected by the deposition of scale.
3. "Dry type" structure to isolate spring and other components with rubber ring seals, the hot water cannot reach the spring when pressure relief, which avoids pressure change caused by sediment adhere to the surface of the spring, and avoids malfunction of the valve.
4. The precise reset guiding mechanism, it can automatically reset quickly even after a great pressure relief.



Specifications

- Opening Temperature: 93°C ~ 99°C
- Resetting Temperature: $\geq 70^\circ\text{C}$
- Pressure Rating: 500Kpa、600Kpa、700Kpa、850Kpa、1000Kpa、1200Kpa、1400Kpa
- Resetting Pressure: $\geq 90\%$ of the opening pressure
- Water-touching metal materials: DZR Brass
- DN size: 15mm(1/2") 20mm(3/4")
- Expansion rating: 15mm(10KW), 20mm(46KW)
- Standards compliant: AS1357.1



Working Curve & Dimension

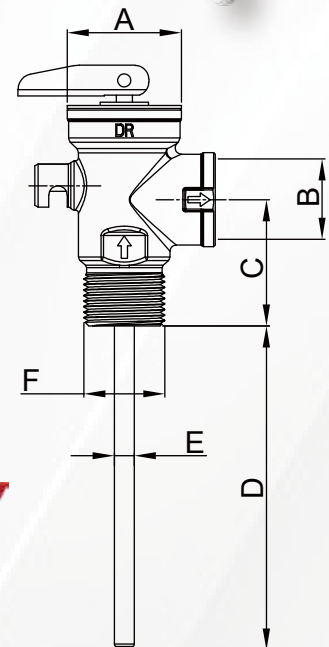
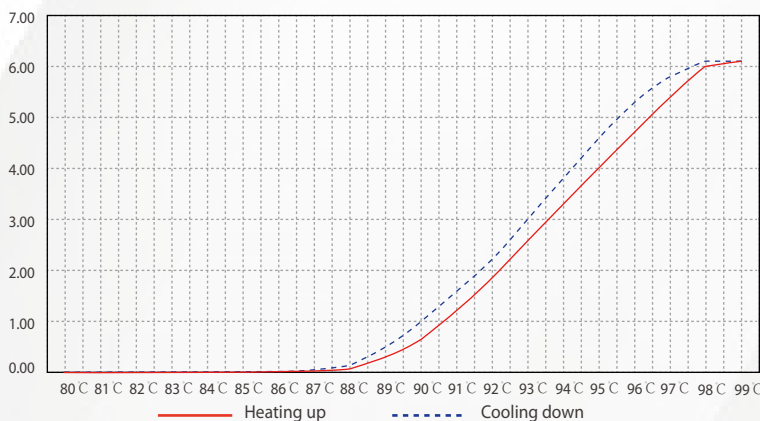

Model Number	Size	DIMENSIONS						Expansion Rating
		A(mm)	B	C(mm)	D(mm)	E(mm)	F	
930007NT	1/2"	$\varnothing 37$	Rp1/2"	51	94	$\varnothing 7$	R1/2"	10KW
930004NT	3/4"	$\varnothing 37$	Rp3/4"	41	105	$\varnothing 7$	R3/4"	46KW



Installation

- * Flush out your lines to remove any debris or dirt particles that may cause the valve to malfunction.
 - * If the valve probe is damaged in any way do not install the valve. Return it to your valve supplier and obtain a replacement. Clean out any foreign matter from the threaded inlet water connection to the water heater.
 - * In addition to these instructions, PTR Valves must be installed in accordance with AS/NZS3500 National Plumbing and Drainage Code. All local government requirements must be met and the PTR must be installed in line with the water heater manufacturer's instructions. Valve rated to 10Kw.
 - * The PTR valve to be fitted must comply with the water heater manufacturer's rating label. The kw rating of the valve should be greater than the kw rating of the water heater. All this information is found on the rating plate of the valve, and on the rating label on the side of the heater.
1. Apply thread seal tape to the thread. Be sure not to use excessive amounts of thread seal that could hang over the thread, break off and lodge under the valve seat, causing it to leak.
 2. Screw the valve into the PTR socket. Do not use a wrench on the valve body. Use the spanner flats provided.
 3. No valve, taps, or other isolating valves are to be fitted between the PTR and the water heater.
 4. Install a drain line of the same nominal pipe size as the valve, in accordance with AS/NZS3500.4. The drain line must have a continuous fall.
 5. Test the manual relief by lifting the lever. Water should out of the relief valve. It is recommended that the manual relief be operated every 6months, so as to flush out any deposits that may accumulate under the seal.
- ⚠ CAUTION: "Danger of scalding" This valve relieves hot water.



Controlled pressure hot water system installation

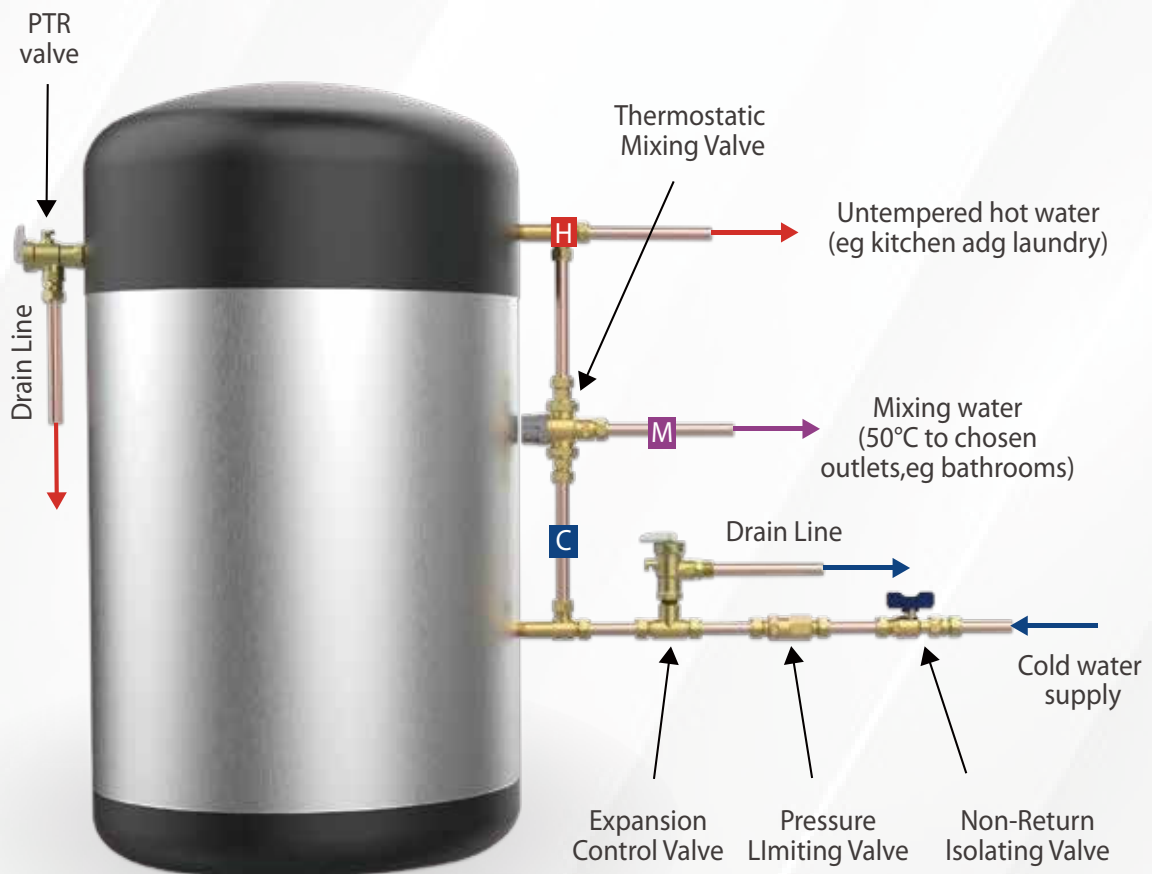

LEGEND

■ =HOT ■ =Cold ■ =Mix

Drain lines must have continuous fall.

