



920075PL USER MANUAL

Compact design, Easy installation, Low energy consumption



The thermal actuator is primarily used in water underfloor heating systems to control the opening and closing of pipeline valves. It is specifically applied to the electric driving part of manifold branch valves, small valves, and dynamic balancing valves. The actuator operates silently and features a nut connection installation method, which is simple, quick to install, and easy to disassemble.

TECHNICAL SPECIFICATIONS

- Control direction: Normally Closed
- Voltage: 24V 110V 220V
- Power consumption: 2W
- Stroke: $\geq 4\text{mm}$
- Closing and opening time: 3-5mins
- Force: $100\pm 10\text{N}$
- Protection grade: IP41
- Working temperature: -5°C to 60°C
- Adapter: M30x1.5mm
- Cable length: 600MM
- Housing material: PA66+30%GF

PRODUCT DIMENSIONS

Unit: mm

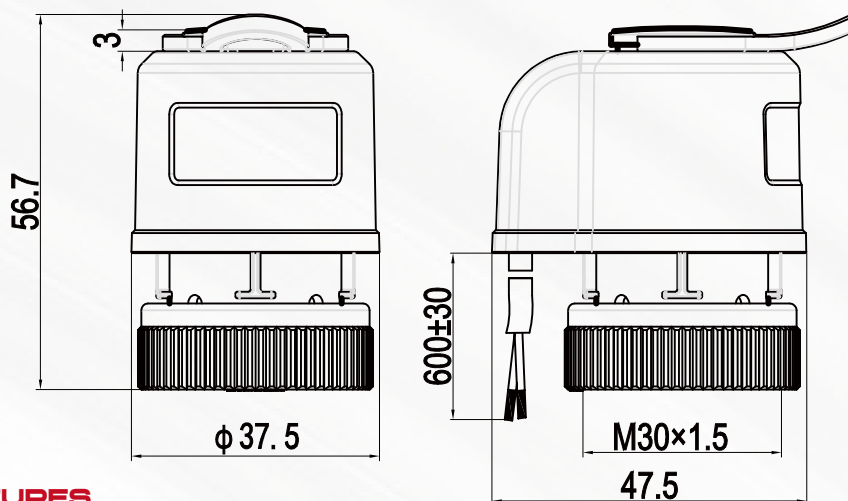

PRODUCT FEATURES

- Compact design
- Easy installation
- Silent operation
- Low energy consumption
- First opening function
- Visual stroke indication

PRODUCT INSTALLATION AND DISASSEMBLY

Product Installation

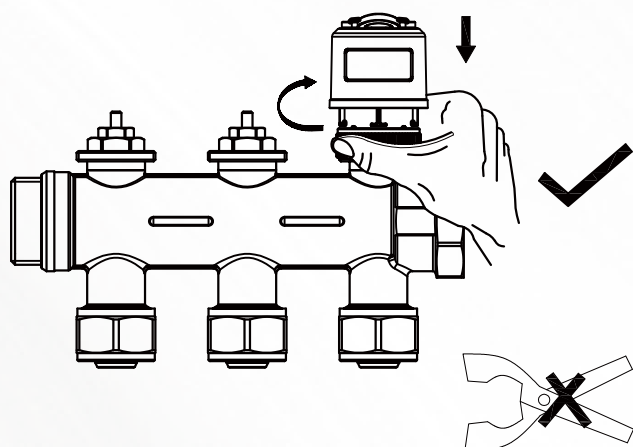

Step 1:

Align the actuator nut with the valve core thread, with the front of the actuator facing outward, and press down on the actuator.

Note: Do not use pipe wrenches.

Step 2:

Rotate the actuator nut clockwise until it feels tight and cannot be turned further.

Step 3:

Ensure that the actuator is installed in place as shown in the diagram.

Product Disassembly

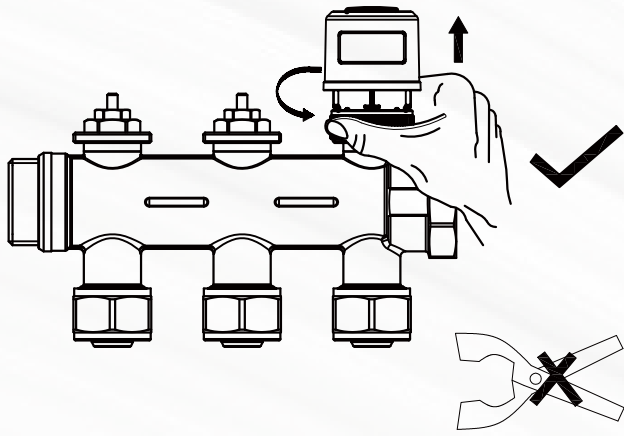

Step 1:

Rotate the actuator nut counterclockwise and push up along the valve core spring until the actuator is removed.

Note: Do not use pipe wrenches, pliers, or other tools during the disassembly process.

INSTALLATION AND DEBUGGING NOTES

Product Indicator Cover Status Confirmation

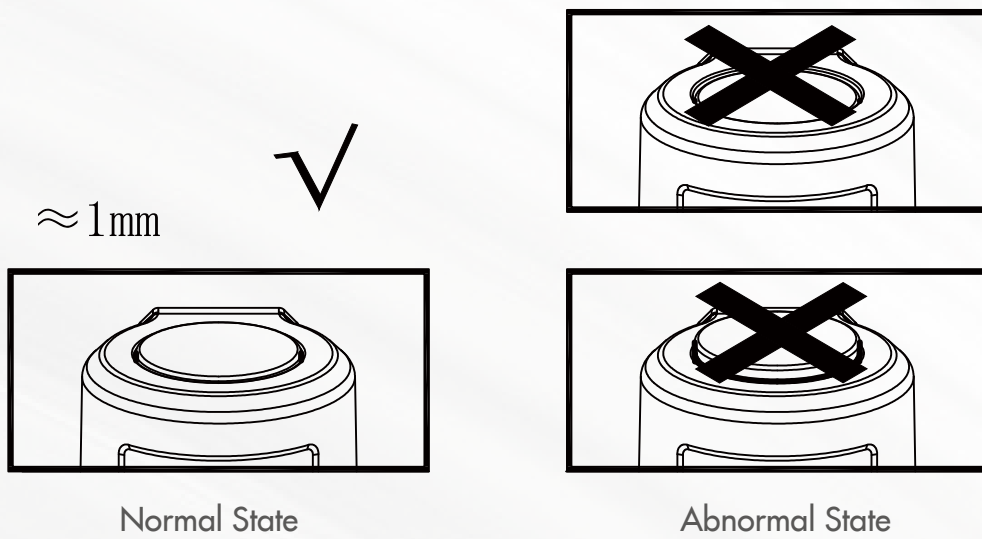

Product Operating Status

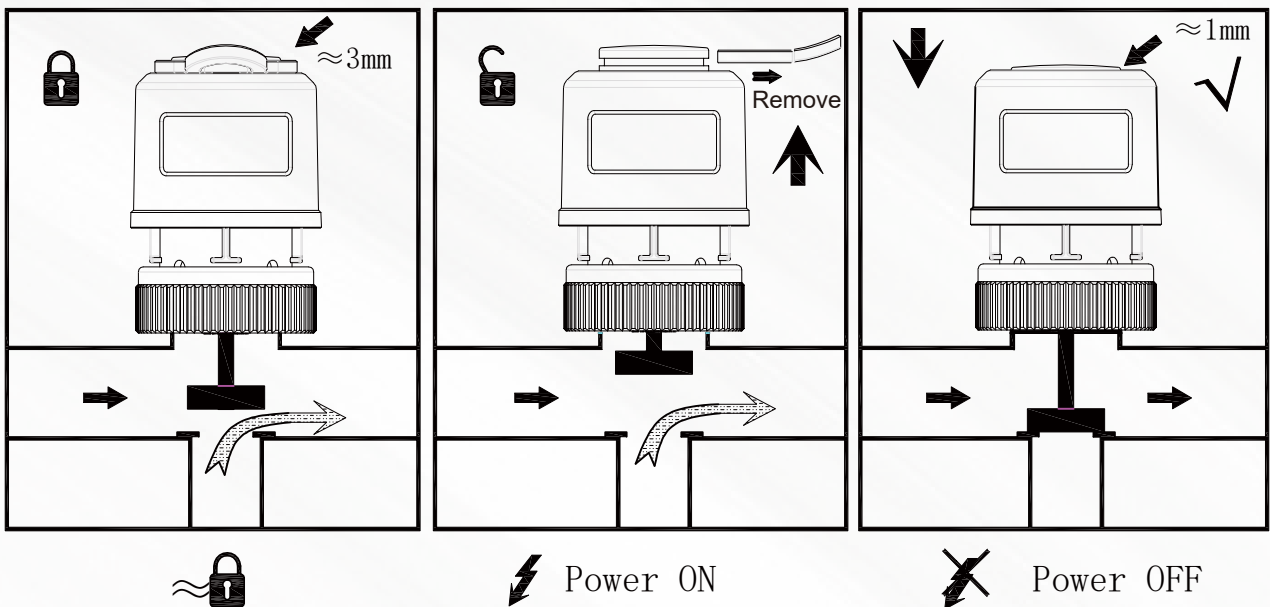

Normally Closed (Initial Installation Power On/Off Indication)